

**FEATURES**

- Low cost integrated amplifier with step attenuator
- Attenuation Range: 0-58 dB, adjustable in 1dB increments via a 3 wire serial control
- Meets DOCSIS distortion requirements at a +60dBmV output signal level
- Programmable address allows multiple parts to share control bus
- Low distortion and low noise
- Frequency range: 5-100MHz
- 5 Volt operation
- -40 to +85 °C temperature range

**APPLICATIONS**

- MCNS/DOCSIS Compliant Cable Modems
- CATV Interactive Set-Top Box
- Telephony over Cable Systems
- OpenCable Set-Top Box
- Residential Gateway



**PRODUCT DESCRIPTION**

The ARA2000 is designed to provide the reverse path amplification and output level control functions in a CATV Set-Top Box or Cable Modem. It incorporates a digitally controlled precision step attenuator that is preceded by an ultra low noise amplifier stage, and followed by an ultra-linear output driver amplifier. This device uses a balanced circuit design that exceeds the

MCNS/DOCSIS requirement for harmonic performance at a +60dBmV output level while only requiring a single polarity +5V supply. Both the input and output are matched to 75 ohms with an appropriate transformer. The precision attenuator provides up to 58 dB of attenuation in 1 dB increments. The ARA2000 has a programmable address that allows multiple devices to share a common control bus. The ARA2000 is offered in a 28-pin SSOP package featuring a heat slug on the bottom of the package.

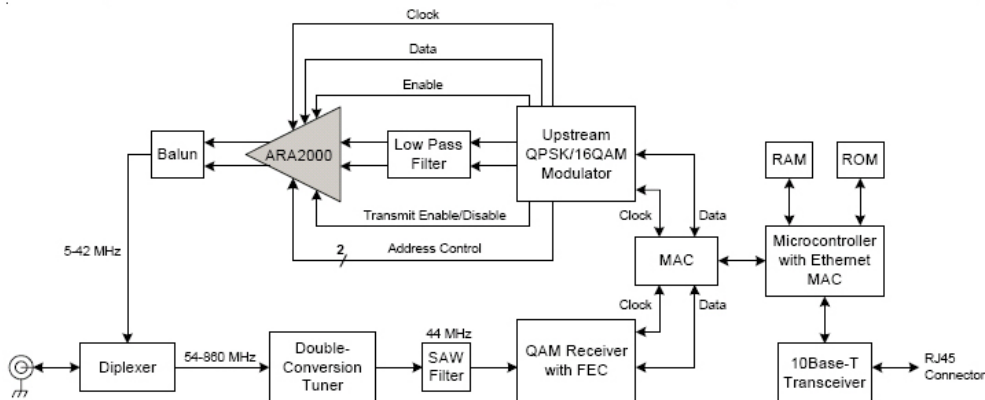

**Figure 1: Cable Modem or Set Top Box Application Diagram**

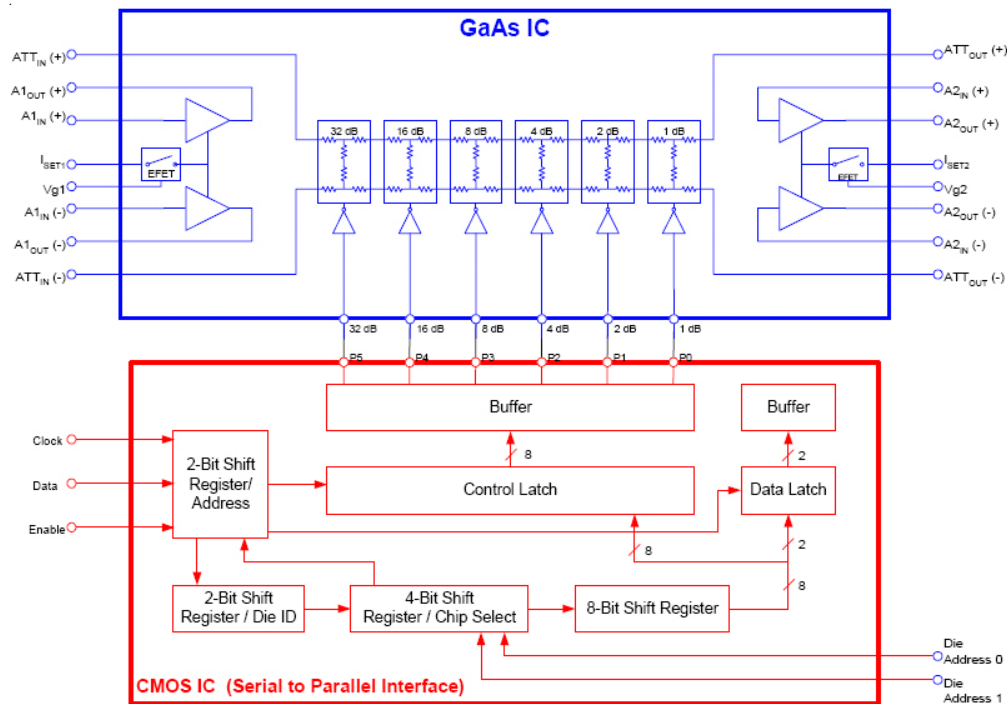

Figure 2: Functional Block Diagram

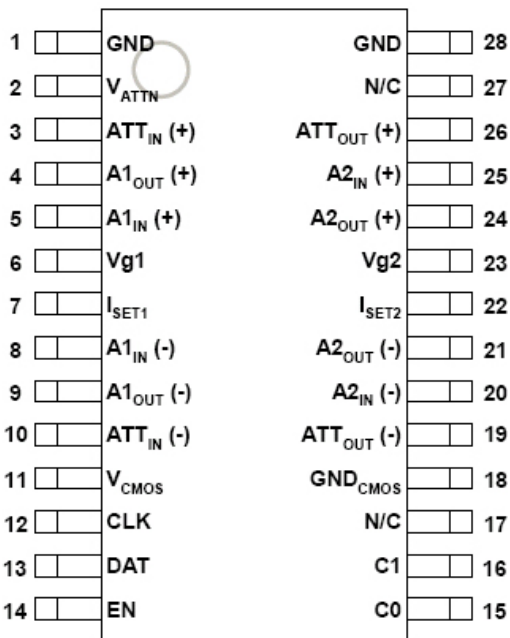

Figure 3: Pin Out

Table 1: Pin Description

PIN	NAME	DESCRIPTION	PIN	NAME	DESCRIPTION
1	GND	Ground	15	C0	Device Address 0
2	V <sub>ATTN</sub>	Supply for Attenuator	16	C1	Device Address 1
3	ATT <sub>IN</sub> (+)	Attenuator (+) Input <sup>(2)</sup>	17	N/C	No Connection <sup>(1)</sup>
4	A1 <sub>OUT</sub> (+)	Amplifier A1 (+) Output	18	GND <sub>CMOS</sub>	Ground for Digital CMOS Circuit
5	A1 <sub>IN</sub> (+)	Amplifier A1 (+) Input <sup>(2)</sup>	19	ATT <sub>OUT</sub> (-)	Attenuator (-) Output <sup>(2)</sup>
6	Vg1	Amplifier A1 (+/-) Control	20	A2 <sub>IN</sub> (-)	Amplifier A2 (-) Input <sup>(2)</sup>
7	ISET1	Amplifier A1 (+/-) Current Adjust	21	A2 <sub>OUT</sub> (-)	Amplifier A2 (-) Output
8	A1 <sub>IN</sub> (-)	Amplifier A1 (-) Input <sup>(2)</sup>	22	ISET2	Amplifier A2 (+/-) Current Adjust
9	A1 <sub>OUT</sub> (-)	Amplifier A1 (-) Output	23	Vg2	Amplifier A2 (+/-) Control
10	ATT <sub>IN</sub> (-)	Attenuator (-) Input <sup>(2)</sup>	24	A2 <sub>OUT</sub> (+)	Amplifier A2 (+) Output
11	V <sub>CMOS</sub>	Supply For Digital CMOS Circuit	25	A2 <sub>IN</sub> (+)	Amplifier A2 (+) Input <sup>(2)</sup>
12	CLK	Clock	26	ATT <sub>OUT</sub> (+)	Attenuator (+) Output <sup>(2)</sup>
13	DAT	Data	27	N/C	No Connection <sup>(1)</sup>
14	EN	Enable	28	GND	Ground

## Notes:

(1) All N/C pins should be grounded.

(2) Pins should be AC-coupled. No external DC bias should be applied.

## ELECTRICAL CHARACTERISTICS

Table 2: Absolute Minimum and Maximum Ratings

PARAMETER	MIN	MAX	UNIT
Analog Supply (pins 2, 4, 9, 21, 24)	0	9	VDC
Digital Supply: $V_{CMOS}$ (pin 11)	0	6	VDC
Amplifier Controls $V_{g1}$ , $V_{g2}$ (pins 6, 23)	-5	2	V
RF Power at Inputs (pins 5, 8)	-	+60	dBmV
Digital Interface (pins 12, 13, 14, 15, 16)	-0.5	$V_{CMOS}+0.5$	V
Storage Temperature	-55	+200	□
Soldering Temperature	-	260	□
Soldering Time	-	5	Sec

Stresses in excess of the absolute ratings may cause permanent damage. Functional operation is not implied under these conditions. Exposure to absolute ratings for extended periods of time may adversely affect reliability.

## Notes:

1. Pins 3, 5, 8, 10, 19, 20, 25 and 26 should be AC-coupled. No external DC bias should be applied.
2. Pins 7 and 22 should be grounded or pulled to ground through a resistor. No external DC bias should be applied.

Table 3: Operating Ranges

PARAMETER	MIN	TYP	MAX	UNIT
Amplifier Supply: $V_{DD}$ (pins 4, 9,21,24)	4.5	5.0	7.0	VDC
Attenuator Supply: $V_{ATTN}$ (pin 2)	$V_{DD} - 0.5$	5.0	7.0	VDC
Digital Supply: $V_{CMOS}$ (pin 11)	3.0	-	5.5	VDC
Digital Interface (pins 12, 13, 14, 15,16)	0	-	$V_{CMOS}$	V
Amplifier Controls $V_{g1}$ , $V_{g2}$ (pins 6, 23)	-5	1	2	V
Case Temperature	-40	25	85	□

The device may be operated safely over these conditions; however, parametric performance is guaranteed only over the conditions defined in the electrical specifications.

Table 4: DC Electrical Specifications

T<sub>A</sub>=25°C; V<sub>DD</sub>, V<sub>ATTN</sub>, V<sub>CMOS</sub> = +5.0 VDC; Vg1, Vg2 = +1.0 V (Tx enabled); Vg1, Vg2 = 0 V (Tx disabled)

PARAMETER	MIN	TYP	MAX	UNIT	COMMENTS
Amplifier A1 Current (pins 4, 9)	- -	48 2.4	80 6	mA	Tx enabled Tx disabled
Amplifier A2 Current (pins 21, 24)	- -	77 3.7	120 9	mA	Tx enabled Tx disabled
Attenuator Current (pin 2)	-	9	15	mA	
Total Power Consumption	- -	0.67 75	1.08 150	W mW	Tx enabled Tx disabled
Thermal Resistance (θ <sub>Jc</sub> )	-	38	-	°C/W	

Table 5: AC Electrical Specifications

T<sub>A</sub>=25°C; V<sub>DD</sub>, V<sub>ATTN</sub>, V<sub>CMOS</sub> = +5.0 VDC; Vg1, Vg2 = +1.0 V (Tx enabled); Vg1, Vg2 = 0 V (Tx disabled)

PARAMETER	MIN	TYP	MAX	UNIT	COMMENTS
Gain (10 MHz)	27.5	29.3	30.5	dB	0 dB attenuation setting
Gain Flatness	- -	0.75 1.5	- -	dB	5 to 42 MHz 5 to 65 MHz
Gain Variation over Temperature	-	-0.006	-	dB/°C	
Attenuation Steps					
1 dB	0.65	0.83	1.00	dB	Monotonic
2 dB	1.6	1.70	2.05		
4 dB	3.6	3.75	4.0		
8 dB	7.5	7.75	8.0		
16 dB	15.0	15.40	15.8		
32 dB	30.2	30.75	31.3		
Maximum Attenuation	58.6	60.3	-	dB	
2 <sup>nd</sup> Harmonic Distortion Level (10 MHz)	-	-75	-53	dBc	+60 dBmV into 75 Ohms
3 <sup>rd</sup> Harmonic Distortion Level (10 MHz)	-	-60	-53	dBc	+60 dBmV into 75 Ohms
3 <sup>rd</sup> Order Output Intercept	78	-	-	dBmV	
1 dB Gain Compression Point	-	68.5	-	dBmV	
Noise Figure	-	3.0	4.0	dB	Includes input balun loss

Note: As measured in test fixture

## continued: AC Electrical Specifications

$T_A=25^{\circ}\text{C}$ ;  $V_{DD}, V_{ATTN}, V_{CMOS} = +5.0\text{ VDC}$ ;  $V_{g1}, V_{g2} = +1.0\text{ V}$  (Tx enabled);  $V_{g1}, V_{g2} = 0\text{ V}$  (Tx disabled)

PARAMETER	MIN	TYP	MAX	UNIT	COMMENTS
Output Noise Power Active/ No Signal/ Min. Atten. Set Active/ No Signal/ Max. Atten. Set.	- -	- -	-38.5 -53.8	dBmV	Any 160 kHz bandwidth from 5 to 42 MHz
Isolation (45 MHz) in Tx disable mode	-	65	-	dB	Difference in output signal between Tx enable and Tx disable
Differential Input Impedance	-	300	-	Ohms	between pins 5 and 8 (Tx enabled)
Input Impedance	-	75	-	Ohms	with transformer (Tx enabled)
Input Return Loss (75 Ohm characteristic impedance)	- -	-20 -5	-12 -	dB	Tx enabled Tx disabled
Differential Output Impedance	-	300	-	Ohms	between pins 21 and 24
Output Impedance	-	75	-	Ohms	with transformer
Output Return Loss (75 Ohm characteristic impedance)	- -	-17 -15	-12 -10	dB	Tx enabled Tx disabled
Output Voltage Transient Tx enable/ Tx disable	- -	- 4	100 7	mVp-p	0 dB attenuator setting 24 dB attenuator setting

Note: As measured in test fixture

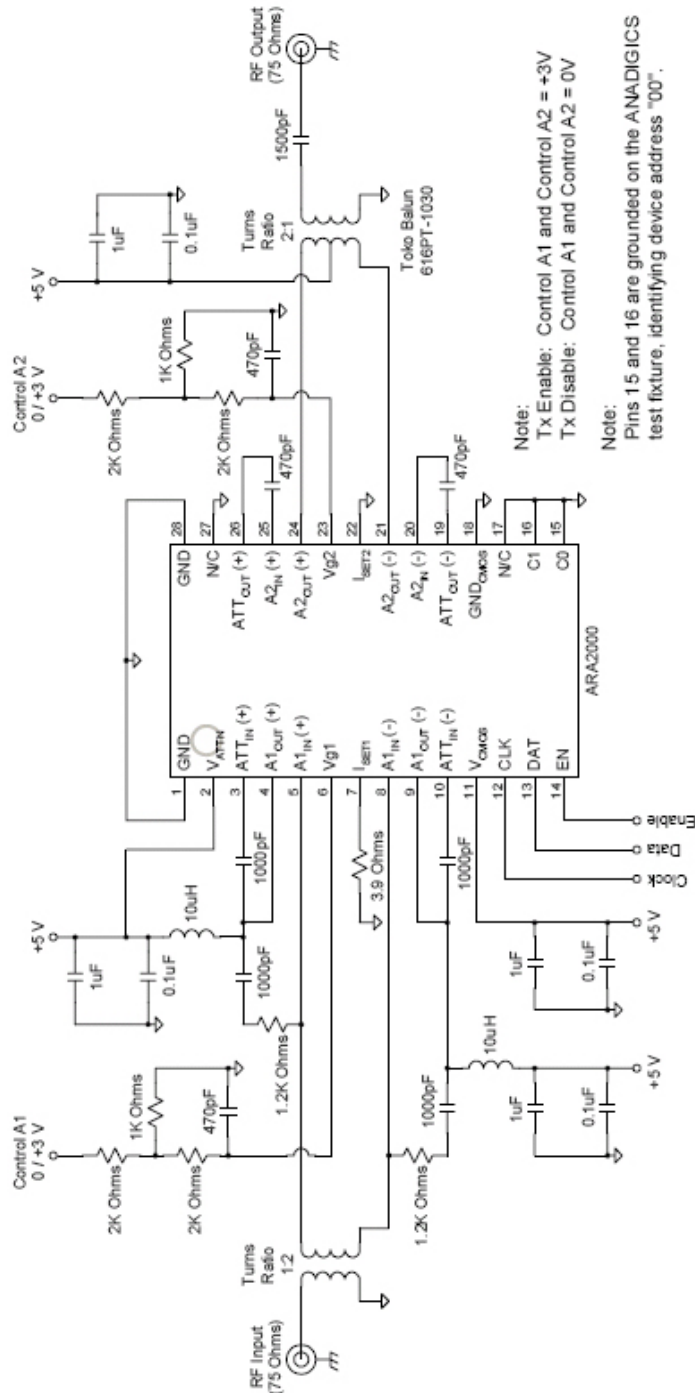

Figure 4: Test Circuit

PERFORMANCE DATA

Figure 5: Attenuation Level vs Control Word

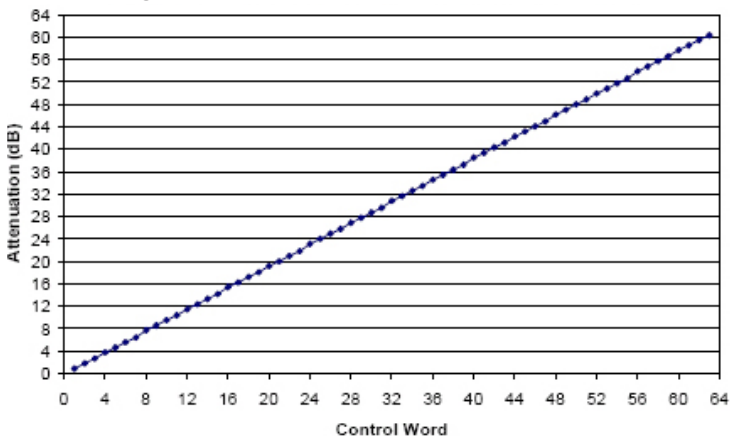

Figure 6: Gain & Noise Figure vs Frequency

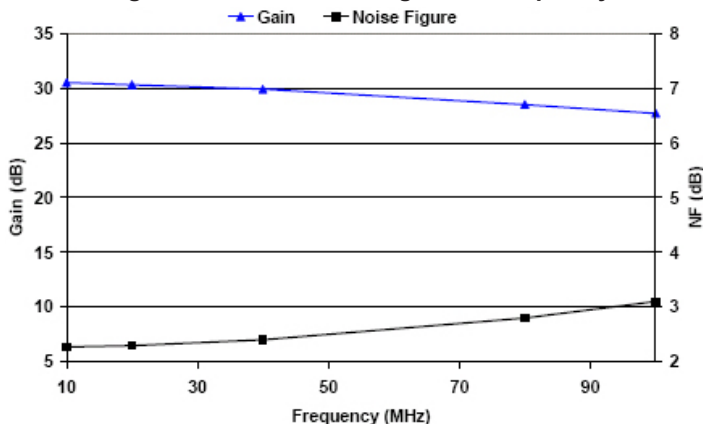

Figure 7: Gain & Noise Figure vs V<sub>DD</sub>

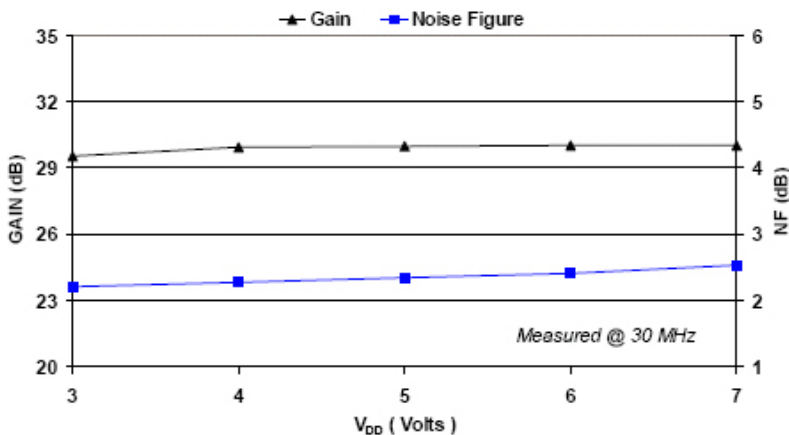



Figure 8: Gain & Noise Figure vs Temperature

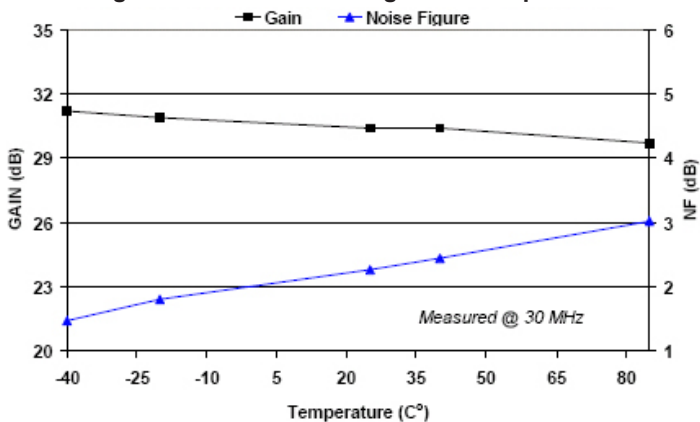

Figure 9: Harmonic Distortion vs V<sub>DD</sub>  
P<sub>OUT</sub> = 58dBmV

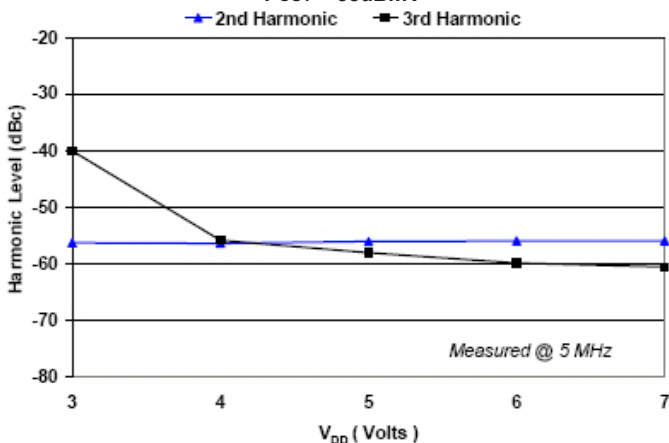
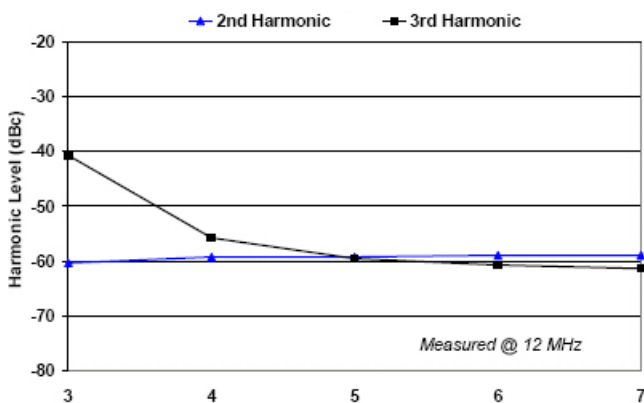
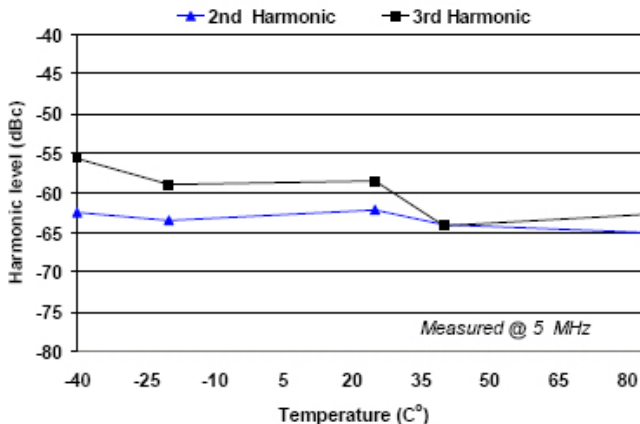

Figure 10: Harmonic Distortion vs V<sub>DD</sub>  
P<sub>OUT</sub> = 58dBmV



**Figure 11: Harmonic Distortion vs Temperature**  
 P<sub>OUT</sub> = 58dBmV



**Figure 12: Harmonic Distortion vs Power Out**

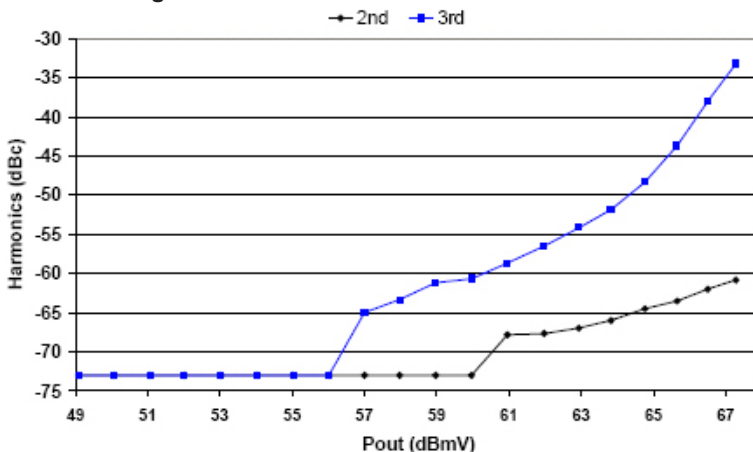

**Figure 13: Transients vs Attenuation**  
 P<sub>OUT</sub> = 55dBmV at 0dB attenuation

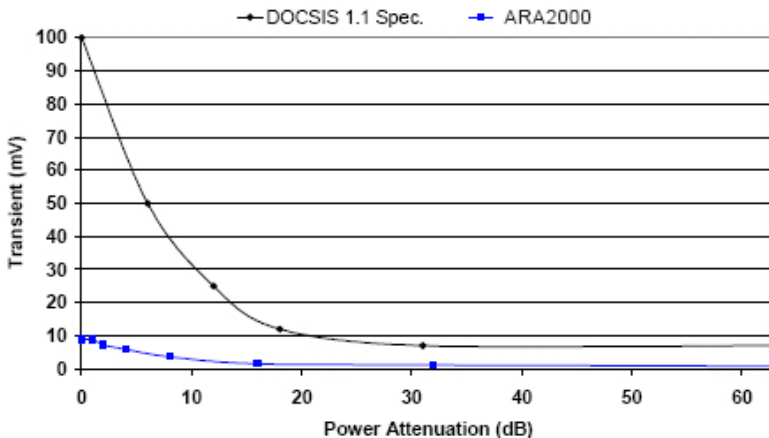

**Figure 14: Harmonic Performance over Frequency** P<sub>OUT</sub> = +62dBmV

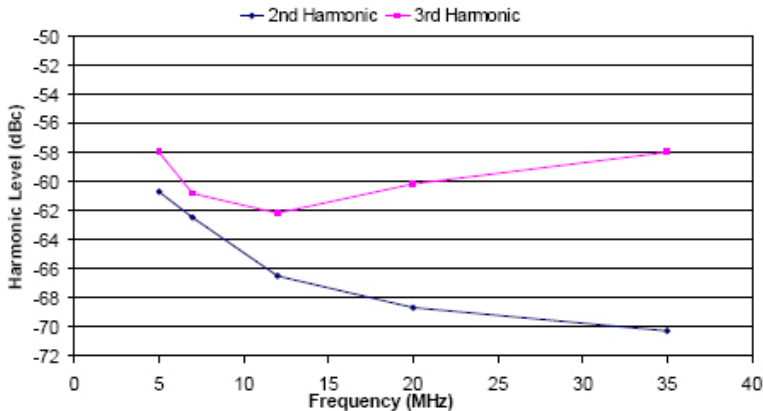

**Figure 15: IIP<sub>2</sub> & IIP<sub>3</sub> vs Frequency**

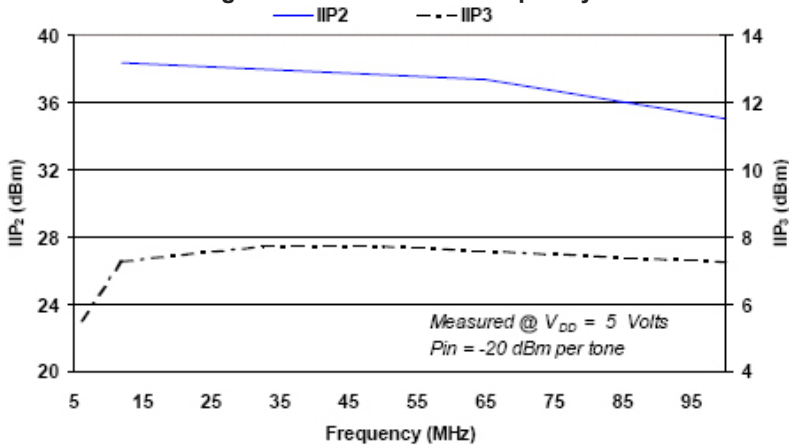

**Figure 16: IIP<sub>2</sub> & IIP<sub>3</sub> vs V<sub>DD</sub>**

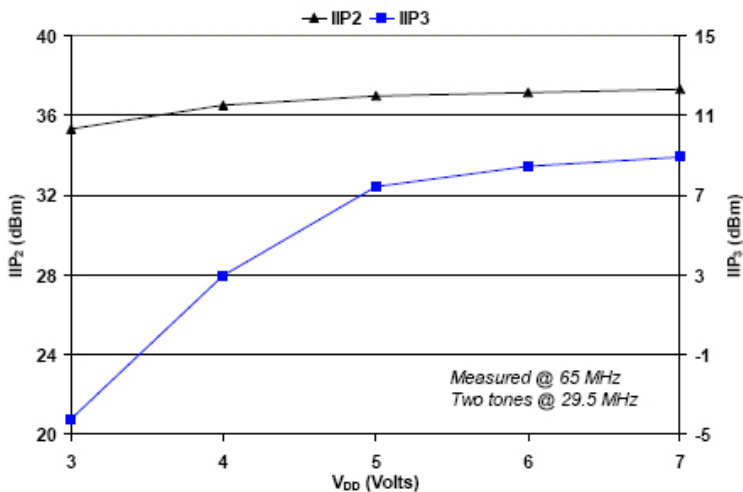

**LOGIC PROGRAMMING**

**Programming Instructions**

The programming word is set through a 16 bit shift register via the data, clock and enable lines. The data is entered in order with the most significant bit (MSB) first and the least significant bit (LSB) last. The

enable line must be low for the duration of the data entry, then set high to latch the shift register. The rising edge of the clock pulse shifts each data value into the register.

**Table 6: Programming Word**

DATA BIT	D15	D14	D13	D12	D11	D10	D9	D8	D7	D6	D5	D4	D3	D2	D1	D0
Value	P7	P6	P5	P4	P3	P2	P1	P0	0	0	0	1	C1	C0	1	1

**Table 7: Data Description**

VALUE	FUNCTION ( 1 = on, 0 = bypass)
P7	N/A
P6	N/A
P5	32 dB Attenuator Bit
P4	16 dB Attenuator Bit
P3	8 dB Attenuator Bit
P2	4 dB Attenuator Bit
P1	2 dB Attenuator Bit
P0	1 dB Attenuator Bit

**Table 8: Device Address**

		LOGIC LEVEL INPUT TO ADDRESS DEVICE	
C1	C0	Pin 16 (C1)	Pin 15 (C0)
0	0	0	0
1	0	1	0
0	1	0	1
1	1	1	1

*The device is selected when the logic inputs at pins 16 and 15 match the values of data bits C1 and C0, respectively.*

Table 9: Digital Interface Specification

PARAMETER	MIN	TYP	MAX	UNIT
Logic High Input: $V_H$	2.0	-	-	V
Logic Low Input: $V_L$	-	-	0.8	V
Logic Input Current Consumption	-	-	0.01	mA
Data to Clock Set Up Time: $t_{CS}$	50	-	-	ns
Data to Clock Hold Time: $t_{CH}$	10	-	-	ns
Clock Pulse Width High: $t_{CWH}$	50	-	-	ns
Clock Pulse Width Low: $t_{CWL}$	50	-	-	ns
Clock to Load Enable Setup Time: $t_{ES}$	50	-	-	ns
Load Enable Pulse Width: $t_{EW}$	50	-	-	ns
Rise Time: $t_R$	-	10	-	ns
Fall Time: $t_F$	-	10	-	ns

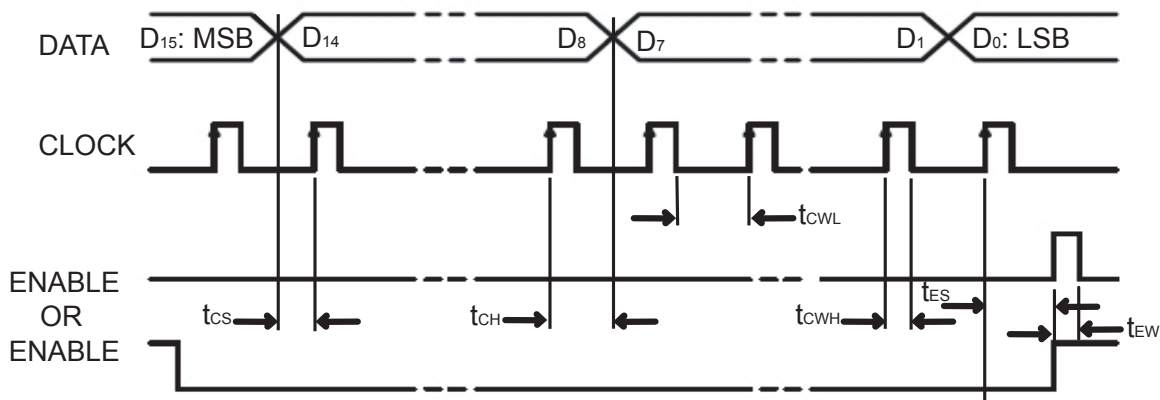

Figure 17: Serial Data Input Timing

**APPLICATION INFORMATION**

**Transmit Enable / Disable**

The ARA2000 includes two amplification stages that each can be shut down through external control pins Vg1 and Vg2 (pins 6 and 23, respectively.) By applying a slightly positive bias of typically +1.0 Volts, the amplifier is enabled. In order to disable the amplifier, the control pin needs to be pulled to ground.

A practical way to implement the necessary control is to use bias resistor networks similar to those shown in the test circuit schematic (Figure 4.) Each network includes a resistor shunted to ground that serves as a pull-down to disable the amplifier when no control voltage is applied. When a positive voltage is applied, the network acts as a voltage divider that presents the required +1.0 Volts to enable the amplifier. By selecting different resistor values for the voltage divider, the network can accommodate different control voltage inputs.

The Vg1 and Vg2 pins may be connected together directly, and controlled through a single resistor network from a common control voltage.

**Amplifier Bias Current**

The ISET pins (7 and 22) set the bias current for the amplification stages. Grounding these pins results in the maximum possible current. By placing a resistor from the pin to ground, the current can be reduced. The recommended bias conditions use the configuration shown in the test circuit schematic in Figure 4.

**Thermal Layout Considerations**

The device package for the ARA2000 features a heat slug on the bottom of the package body. Use of the heat slug is an integral part of the device design. Soldering this slug to the ground plane of the PC board will ensure the lowest possible thermal resistance for the device, and will result in the longest MTF (mean time to failure.)

A PC board layout that optimizes the benefits of the heat slug is shown in Figure 18. The via holes located under the body of the device must be plated through to a ground plane layer of metal, in order to provide a sufficient heat sink. The recommended solder mask outline is shown in Figure 19.

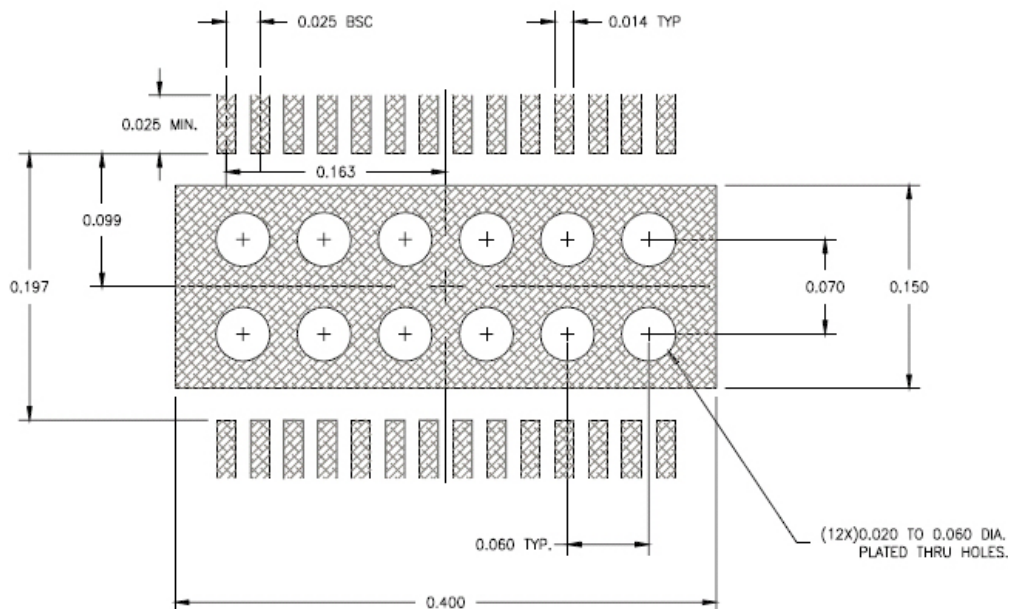

**Figure 18: PC Board Layout**

### Output Transformer

Matching the output of the ARA2000 to a 75 Ohm load is accomplished using a 2:1 turns ratio transformer. In addition to providing an impedance transformation, this transformer provides the bias to the output amplifier stage via the center tap.

The transformer also cancels even mode distortion products and common mode signals, such as the voltage transients that occur while enabling and disabling the amplifiers. As a result, care must be taken when selecting the transformer to be used at the output. It must be capable of handling the RF and DC power requirements without saturating the core,

and it must have adequate isolation and good phase and amplitude balance. It also must operate over the desired frequency and temperature range for the intended application.

### ESD Sensitivity

Electrostatic discharges can cause permanent damage to this device. Electrostatic charges accumulate on test equipment and the human body, and can discharge without detection. Proper precautions and handling are strongly recommended. Refer to the application note on ESD precautions.

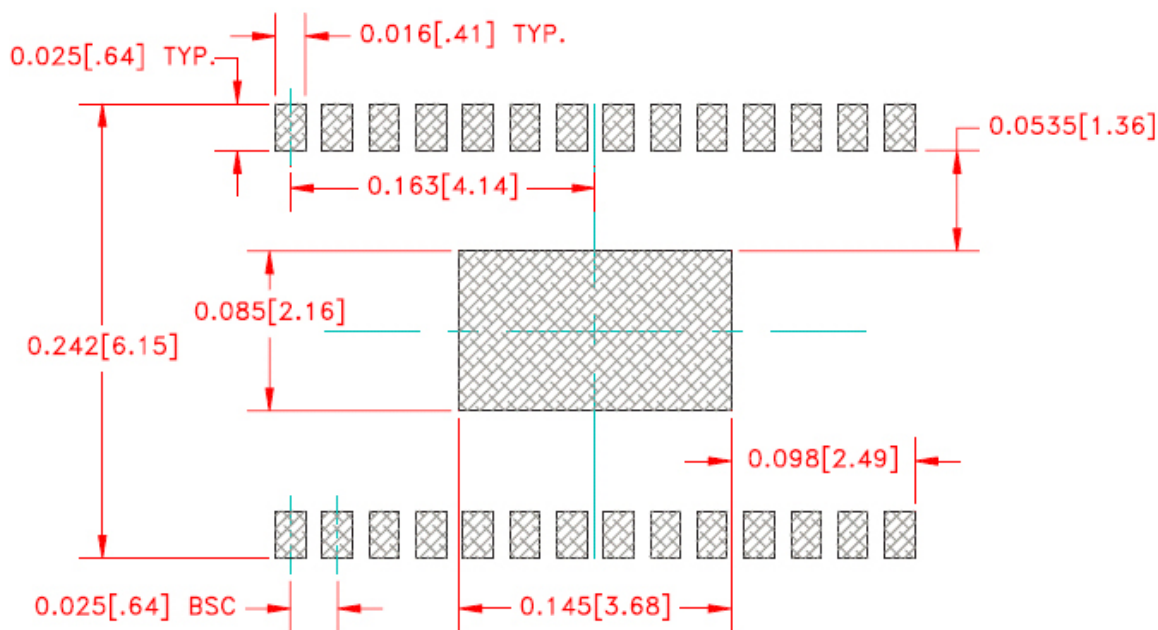
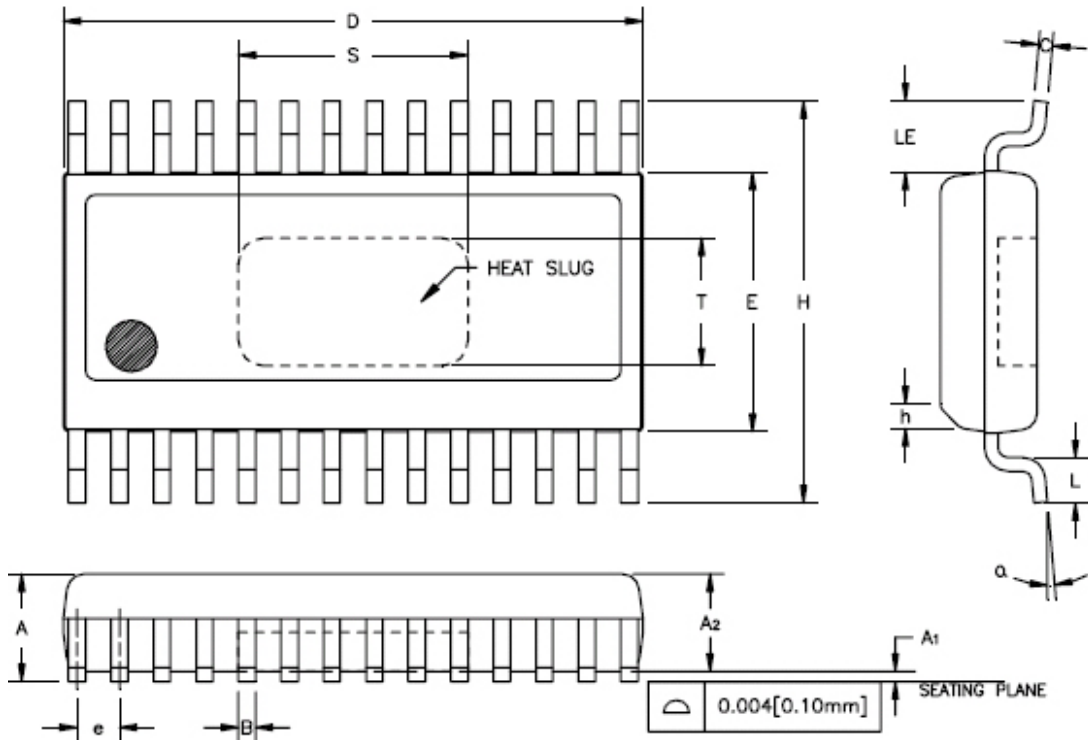

Figure 19: Solder Mask Outline

PACKAGE OUTLINE



Symbol	INCHES		MILLIMETERS		NOTE
	MIN.	MAX.	MIN.	MAX.	
A	0.058	0.068	1.47	1.73	
A1	0.000	0.004	0.00	0.10	
A2	0.054	0.060	1.37	1.52	
B	0.008	0.014	0.20	0.35	5
C	0.007	0.012	0.18	0.30	5
D	0.385	0.393	9.78	9.98	2
E	0.151	0.157	3.84	3.99	3
e	0.025 BSC		0.64 BSC		4
H	0.228	0.244	5.79	6.20	
h	0.015x45°		0.38x45°		
L	0.016	0.032	0.41	0.81	
LE	0.042	—	1.07	—	
alpha	0°	8°	0°	8°	
S	0.105	0.135	2.67	3.43	6
T	0.045	0.075	1.41	1.91	6

NOTES:

1. CONTROLLING DIMENSION: INCHES
2. DIMENSION "D" DOES NOT INCLUDE MOLD FLASH, PROTRUSIONS OR GATE BURRS. MOLD FLASH, PROTRUSIONS AND GATE BURRS SHALL NOT EXCEED 0.006 [0.15mm] PER SIDE.
3. DIMENSION "E" DOES NOT INCLUDE INTER-LEAD FLASH OR PROTRUSIONS. INTER-LEAD FLASH AND PROTRUSIONS SHALL NOT EXCEED 0.010 [0.25mm] PER SIDE.
4. MAXIMUM LEAD TWIST/SKEW TO BE ±0.0035 [0.089mm].
5. LEAD WIDTH "B" AND THICKNESS "C" MAX. DIMENSION IS AFTER PLATING.
6. DIMENSIONS "S" AND "T" INDICATE EXPOSED SLUG AREA.

Figure 20: S12 Package Outline - 28 Pin SSOP with Heat Slug



**COMPONENT PACKAGING**

Volume quantities of the ARA2000 are supplied on tape and reel. Each reel holds 3,500 pieces.

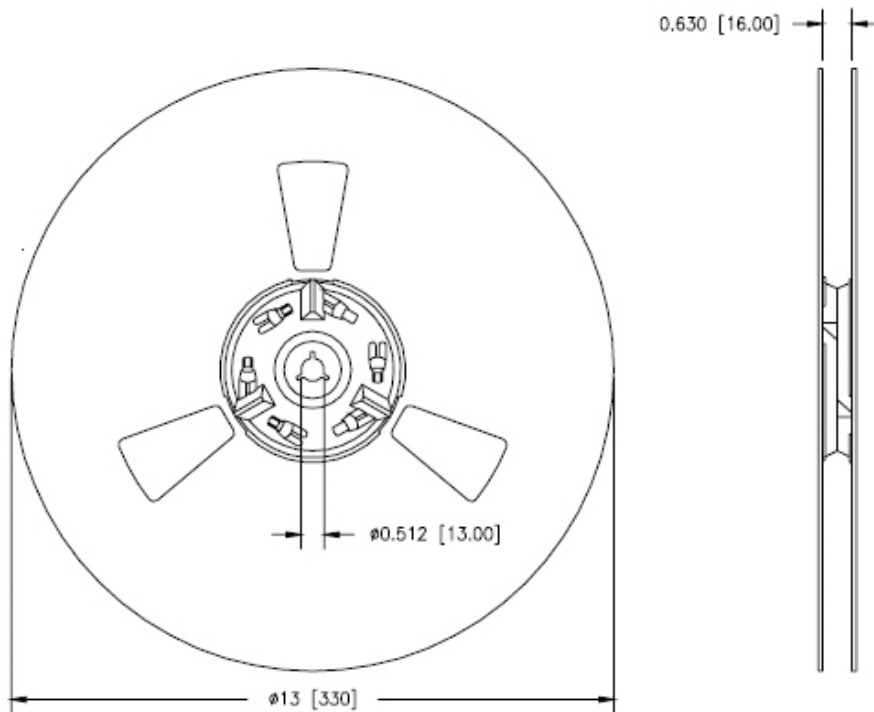

**Figure 21: Reel Dimensions**

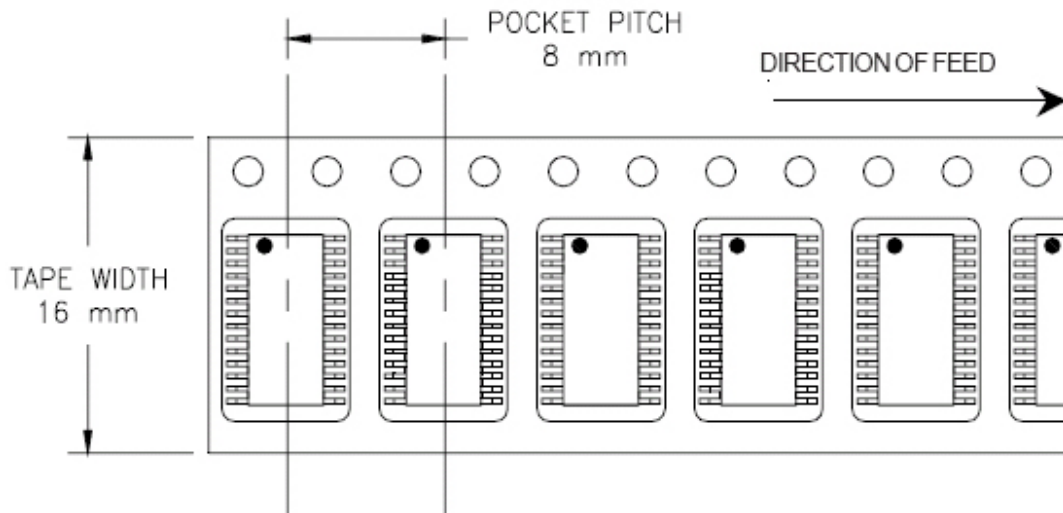

**Figure 22: Tape Dimensions**

**ORDERING INFORMATION**

<b>ORDER NUMBER</b>	<b>TEMPERATURE RANGE</b>	<b>PACKAGE DESCRIPTION</b>	<b>COMPONENT PACKAGING</b>
ARA2000S12P1	-40 to 85 °C	28 Pin SSOP with Heat Slug	3,500 piece tape and reel

NOTES

---

Copyright © 2016 Skyworks Solutions, Inc. All Rights Reserved.

Information in this document is provided in connection with Skyworks Solutions, Inc. ("Skyworks") products or services. These materials, including the information contained herein, are provided by Skyworks as a service to its customers and may be used for informational purposes only by the customer. Skyworks assumes no responsibility for errors or omissions in these materials or the information contained herein. Skyworks may change its documentation, products, services, specifications or product descriptions at any time, without notice. Skyworks makes no commitment to update the materials or information and shall have no responsibility whatsoever for conflicts, incompatibilities, or other difficulties arising from any future changes.

No license, whether express, implied, by estoppel or otherwise, is granted to any intellectual property rights by this document. Skyworks assumes no liability for any materials, products or information provided hereunder, including the sale, distribution, reproduction or use of Skyworks products, information or materials, except as may be provided in Skyworks Terms and Conditions of Sale.

THE MATERIALS, PRODUCTS AND INFORMATION ARE PROVIDED "AS IS" WITHOUT WARRANTY OF ANY KIND, WHETHER EXPRESS, IMPLIED, STATUTORY, OR OTHERWISE, INCLUDING FITNESS FOR A PARTICULAR PURPOSE OR USE, MERCHANTABILITY, PERFORMANCE, QUALITY OR NON-INFRINGEMENT OF ANY INTELLECTUAL PROPERTY RIGHT; ALL SUCH WARRANTIES ARE HEREBY EXPRESSLY DISCLAIMED. SKYWORKS DOES NOT WARRANT THE ACCURACY OR COMPLETENESS OF THE INFORMATION, TEXT, GRAPHICS OR OTHER ITEMS CONTAINED WITHIN THESE MATERIALS. SKYWORKS SHALL NOT BE LIABLE FOR ANY DAMAGES, INCLUDING BUT NOT LIMITED TO ANY SPECIAL, INDIRECT, INCIDENTAL, STATUTORY, OR CONSEQUENTIAL DAMAGES, INCLUDING WITHOUT LIMITATION, LOST REVENUES OR LOST PROFITS THAT MAY RESULT FROM THE USE OF THE MATERIALS OR INFORMATION, WHETHER OR NOT THE RECIPIENT OF MATERIALS HAS BEEN ADVISED OF THE POSSIBILITY OF SUCH DAMAGE.

Skyworks products are not intended for use in medical, lifesaving or life-sustaining applications, or other equipment in which the failure of the Skyworks products could lead to personal injury, death, physical or environmental damage. Skyworks customers using or selling Skyworks products for use in such applications do so at their own risk and agree to fully indemnify Skyworks for any damages resulting from such improper use or sale.

Customers are responsible for their products and applications using Skyworks products, which may deviate from published specifications as a result of design defects, errors, or operation of products outside of published parameters or design specifications.

Customers should include design and operating safeguards to minimize these and other risks. Skyworks assumes no liability for applications assistance, customer product design, or damage to any equipment resulting from the use of Skyworks products outside of stated published specifications or parameters.

Skyworks and the Skyworks symbol are trademarks or registered trademarks of Skyworks Solutions, Inc., in the United States and other countries. Third-party brands and names are for identification purposes only, and are the property of their respective owners. Additional information, including relevant terms and conditions, posted at [www.skyworksinc.com](http://www.skyworksinc.com), are incorporated by reference.

**Skyworks Solutions, Inc.**

Phone [781] 376-3000 • Fax [781] 376-3100 • [sales@skyworksinc.com](mailto:sales@skyworksinc.com) • [www.skyworksinc.com](http://www.skyworksinc.com)

Skyworks Proprietary and Confidential information • Products and Product Information are Subject to Change Without Notice